

INTRODUCTION OF LORA COMMUNICATION SYSTEM AND REMOTE CONTROL SYSTEM IN AGRICULTURAL AUTOMATION WITH INTERNET OF THINGS

Yani Prabowo¹, Jan Everhard Riwurohi², Wiwin Windihastuti³ and Fuad Hasan⁴

¹ Universitas Budi Luhur, Indonesia

² Universitas Budi Luhur, Indonesia

³ Universitas Budi Luhur, Indonesia

⁴ Simor, Indonesia

Corresponding Author:

Yani Prabowo, Universitas
Budi Luhur.

Jl. Ciledug Raya, RT.10/RW.2, Petukangan Utara, Kec. Pesanggrahan, Kota Jakarta Selatan, Daerah Khusus Ibukota Jakarta 12260

Email: dean.bsc@karwan.edu.af

Article Info

Received: October 10, 2024

Revised: December 25, 2024

Accepted: March 20, 2025

Online Version: April 15, 2025

Abstract

This research focuses on the integration of LoRa (Long Range) communication system and remote control system in agricultural automation with Internet of Things (IoT) using ESP32 microcontroller, Arduino nano and STM32 aims to improve the efficiency of intelligent agricultural management. LoRa is used as a long-range wireless communication protocol to collect data from sensors that are widely distributed in agricultural land, such as soil moisture sensors, temperature. The ESP32 microcontroller functions as the main controller that processes data from sensors and sends it in real-time to the control center via the LoRa network. Modbus is used as a standard serial communication protocol to connect sensors, actuators and other devices, thus ensuring compatibility between devices. In addition, Node-RED is used as a graphical interface (GUI) to manage data flow, control automation processes, and provide real-time data visualization to users. The results of this research are a stable integration system between sensor systems and communication systems. The novelty of this research is the integration of LoRa, ESP32, Modbus, and Node-RED to create a reliable and efficient agricultural automation system, enabling remote management of irrigation, fertilization, and environmental monitoring, thereby increasing agricultural productivity and optimizing resource use.

Keywords: LoRa, Microcontroller, Protocol



© 2025 by the author(s)

This article is an open-access article distributed under the terms and conditions of the Creative Commons Attribution-ShareAlike 4.0 International (CC BY SA) license (<https://creativecommons.org/licenses/by-sa/4.0/>).

Journal Homepage

<https://research.adra.ac.id/index.php/jasca>

How to cite:

Prabowo, Y., Riwurohi, E, J., Windihastuti, W., & Hasan, F. (2025). Introduction of Lora Communication System and Remote Control System in Agricultural Automation With Internet of Things. *Journal of Computer Science Advancements*, 3(2), 100–111. <https://doi.org/10.70177/jasca.v3i2.2230>

Published by:

Yayasan Adra Karima Hubbi

INTRODUCTION

The rapid development of Internet of Things (IoT) technology has created significant changes in almost every industry around the world, one of which is in agriculture (Addabbo, 2019). This transformation changes traditional farming methods that rely on natural conditions with the help of the internet and creates new opportunities (Mo, 2019).

The demand for agricultural products will increase along with the increasing population. With the reduction in human resources in agriculture, the reduction in agricultural land due to the conversion of agricultural land for development, the uncertainty of climate or weather is a reason for automation in agriculture (Anggraini, 2023; Netto, 2022). This paper explores how to build an open source system integration of computer technology and IoT in an agricultural system. Smart agriculture will increase efficiency in agriculture through the use of IoT technology that allows automatic monitoring and control for various environmental conditions (Atawodi, 2023). ESP32 is one of the breakthroughs in low-power microcontroller technology that can be used for IoT systems, but ESP32 cannot be connected directly for communication with the internet network without going through a communication protocol. LORA and data collection from each sensor are then sent to the cloud as data storage. LORA can send data up to a distance of up to 20-30 kilometers in line of sight (LoS) conditions (Batong et al., 2020).

In the implementation of IoT technology for agriculture, communication problems between sensor devices and controllers are often encountered, this is certainly a challenge in itself in how to provide a reliable and low-cost communication network (Meftah, 2024; Meftahi, 2022). LORA is one of the communication technologies that can be applied and how to integrate the ESP32 microcontroller and the LORA network with the Modbus protocol (You, 2022).

In an effort to develop an efficient and effective smart farming system, one of the challenges is to integrate the Modbus protocol with LoRa controlled by ESP32 as the main platform (González, 2023). Modbus is one of the communication protocols widely used in industrial applications to connect sensors and actuators, while LoRa is known for its long-distance communication capabilities with low power consumption (Alam, 2022; Flauzac, 2020). However, combining these two technologies under ESP32 control in the context of agriculture presents several technical problems. How to ensure smooth and reliable communication between Modbus, which is generally used in short-range serial communication, with LoRa which is designed for long-range wireless communication (Mari, 2023). How to integrate the Modbus protocol with LoRa controlled by ESP32 to create an efficient and energy-saving agricultural monitoring system. The purpose of this research is to design an IoT system that utilizes ESP32 as the main platform for connecting sensors with controllers using Modbus and LORA protocols for communication between devices with wide range and low power consumption. This system is designed to monitor various agricultural parameters, such as soil moisture, air temperature, and plant conditions, while enabling automatic control of irrigation and fertilization systems, which can be accessed remotely via an IoT network (Wu, 2019).

Introduced an IoT-based agricultural system that uses the LoRaWAN (Low-Power Wide-Area Network) protocol for long-distance data transmission with low power consumption (Porselvi, 2021). The system is designed to support large-scale agricultural operations by enabling data collection from sensors installed over a wide area and sending it to a cloud service for storage and analysis (Meftah, 2024). LoRaWAN was chosen because it is suitable for environments where external power sources are limited, as it can operate on battery power for long periods of

time (Simitha, 2019). The study highlights the system's ability to monitor parameters such as soil moisture, air temperature, and humidity, providing real-time data for automated farm management processes such as irrigation control (Siregar, 2020). The study emphasizes the flexibility and scalability of the system, which is designed to handle an ever-expanding number of devices and data points, making it adaptive to a variety of agricultural needs (Scherer, 2022).

Research by Sangsuwan (2020) developed an agricultural monitoring system based on Zigbee wireless communication and Programmable Logic Controllers (PLC) using the Modbus RTU protocol. This system consists of a weather station that monitors environmental parameters such as temperature, air humidity, soil moisture, and wind speed. The weather station uses solar energy and communicates with an indoor server via a Zigbee network. The implementation of this system shows advantages in terms of low cost, good stability, and reliable wireless communication up to a distance of 200 meters. This system is ideal for large-scale agricultural monitoring. In addition, the study also introduced SDR-LoRa, which is a Software Defined Radio (SDR) implementation of the LoRa protocol which is popular in low-power IoT applications such as smart agriculture. SDR-LoRa offers flexibility for long-distance communication with low power consumption, and its application is very suitable for precision agriculture. This LoRa protocol has proven to be an efficient solution in IoT-based agricultural monitoring, especially for large scales (Koodtalang & Sangsuwan, 2020).

Another study by Zare and Iqbal (2020) developed a low-cost Supervisory Control and Data Acquisition (SCADA) for home automation using ESP32, Raspberry Pi, and MQTT protocol. Although this system is designed for home automation, the low-cost IoT architecture and principles applied are also relevant for agricultural monitoring. The system utilizes analog sensors to incorporate environmental variables such as temperature, humidity, and light intensity, highlighting the advantages of using low-power and low-cost IoT devices for real-time monitoring (2020; Zare & Iqbal, 2020).

IoT technology is capable of revolutionizing traditional farming methods towards smart farming. By utilizing big data, cloud computing, and IoT, processes such as irrigation and monitoring can be optimized, ultimately increasing agricultural efficiency and productivity. This study emphasizes the important role of IoT in reducing resource consumption and increasing agricultural yields (Simanjuntak, 2023). This platform uses open-source hardware based on ESP32 and Node-RED to support distance learning. It allows students to control real laboratory equipment remotely, emphasizing the development of self-learning motivation through creative approaches (Sa'Adah, 2023). This platform is designed to address challenges in higher education, such as resource constraints and increasing student numbers, and offers an affordable alternative to traditional laboratories. This technology also supports IoT integration through secure and reliable communication, allowing students to conduct practical experiments remotely more effectively (González, 2024; Jagadesh, 2023).

Various IoT technologies and communication protocols, particularly in agricultural applications. They emphasized the use of Wireless Sensor Networks (WSN) to enable remote monitoring and control of environmental parameters in smart greenhouses. The study also reviewed protocols such as Zigbee and Wi-Fi which are essential to ensure reliable and energy-efficient data transmission (Biswas, 2021). This approach is considered essential in maintaining optimal conditions in agriculture, including for irrigation management and climate control. In the study, one of the main challenges faced is the energy wastage in wireless communication.

This study examines the optimization of IoT-based wireless sensor networks with LoRa technology for smart agriculture. Being a solution to increase agricultural productivity by using sensors to monitor environmental conditions. This study tests the effectiveness of LoRa technology in various weather conditions, distances, and frequencies, showing that LoRa is very efficient for long-distance communication with low power consumption (Lv, 2023). This technology also offers lower costs for small-scale farmers. This study suggests that LoRa parameter settings can be optimized to improve the efficiency and sustainability of IoT systems in the agricultural sector (Sun, 2024).

RESEARCH METHOD

Research Design

The method used in this study is research and development (R & D) in addition to the current research is the development and renewal of previous research. Designing an architecture that combines Modbus, LoRa, and ESP32 for data collection, processing, and transmission in an agricultural environment. The purpose of this study is focused on designing a product in the form of a minimum system for IoT-based agriculture.

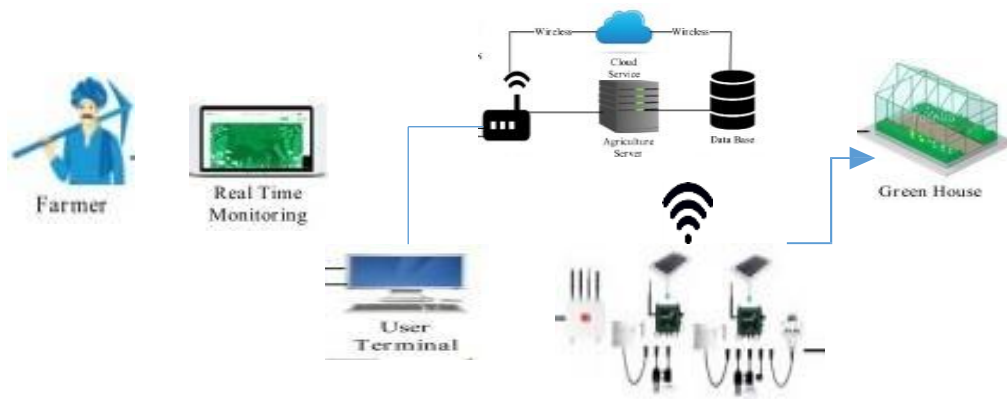

Figure 1. System design

Research Procedure

Simulation and Field Experiments: conducting simulations and field experiments to test system performance in various agricultural environment scenarios, including signal and data transmission conditions. System Performance Evaluation measures metrics such as latency, throughput, energy consumption, and signal stability under actual operational conditions.

Current research is currently underway to design and assemble the electronic circuits used. Figure 2. System implementation is a complete series of this research which will be divided into several separate segments but still in one unit. Among them are; First ESP32 main controller circuit, Second temperature sensor circuit with STM32, Third Actuator circuit with Arduino nano, Fourth Software design.

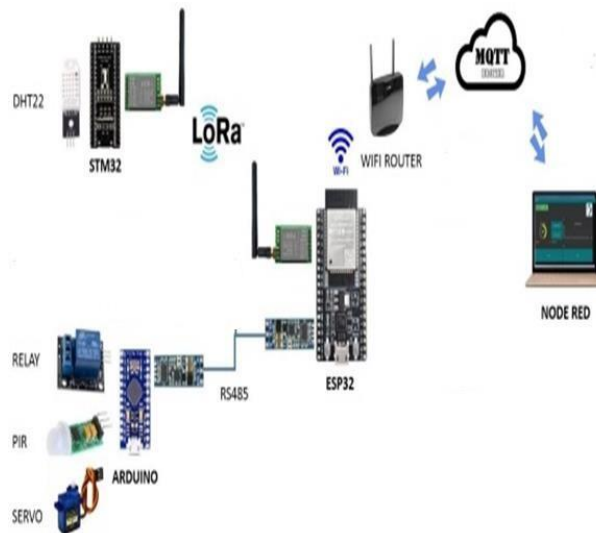

Figure 2. System Implementation

Instruments, and Data Collection Techniques

ESP32 Hardware Circuit

ESP32 in this study is used as the control center of the entire system, ESP32 has the ability to be connected to wifi via a router, a port for RS-485 serial communication and a Lora Module. This circuit is shown in Figure 3.

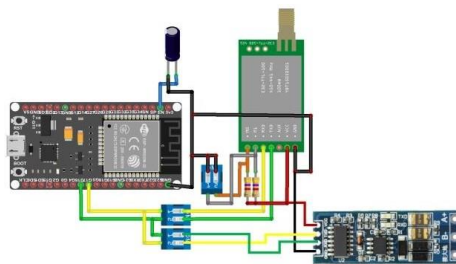

Figure 3. ESP32 dengan LORA

LoRa (Long Range) is a unique and amazing modulation format created by Semtech. The modulation produced uses FM modulation. The core of the processing produces a stable frequency value. The transmission method can also use PSK (Phase Shift Keying), FSK (Frequency Shift Keying) and others. The frequency value on LoRa varies according to the region, if in Asia the frequency used is 433 MHZ, in Europe the frequency value used is 868 MHZ, while in North America the frequency used is 915 MHZ

Temperature Sensor Circuit with STM 32

The temperature sensor does not have the ability to convey data, so a communication device is needed. Lora was chosen as the communication device because it has sufficient capabilities in terms of distance and ease of use. The Lora communication device and temperature sensor cannot be connected directly so an STM32 microcontroller device is needed. This STM32 functions as a slave station only for collecting temperature data. Figure 4 is a schematic of the temperature sensor installation, STM32 microcontroller and LORA. Connected

with serial communication, data ID 1 baudrate 38400 is given with parity 8N1 as the identification address in the system.

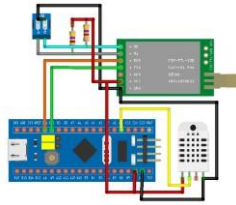

Figure 4. Microcontroller STM32 with LoRa

Actuator circuit with arduino uno

The actuator circuit used for servo motors is an actuator used for precision movement with angular position control. Its function in the circuit is to move objects to a certain angle accurately (usually 0–180° for standard servos). Servos work based on PWM (Pulse Width Modulation) signals from the Arduino microcontroller. The relay functions to automatically disconnect/connect the power supply to the servo motor based on the specified data, especially if the motor requires a large current that cannot be directly supplied by the microcontroller in the circuit in figure 3. The servo motor is connected to pins 2, 1, 5 on the Arduino, the relay is connected to pins 1,4 and the PIR sensor is connected to pins 0, 1, 3 with the Arduino as a slave given the address ID 2. Arduino is positioned as slave 2 connected via RS-485 serially

IoT software

In this study, Node-red is used as a user interface between the user and the system. Node-red was chosen because it is open source, a browser-based programming tool for connecting to hardware, APIs and online services and is easy to develop and apply. Node-red can be downloaded at <https://nodejs.org/en/download/>.



Figure 5. The flow pallet used to create a GUI.

RESULTS AND DISCUSSION

Temperature Testing and Data Transmission via LORA STM32

To display the results of temperature measurements transmitted using LoRa, here is the data showing the temperature collected and sent every 15 minutes, and how the data is received at the LoRa endpoint or gateway. This data is presented in the form of table 1 which includes the measurement time, measured temperature, and transmission status.

Table1. Temperature Measurement and Transmission Results

Waktu Pengukuran	Suhu (°C)	Status Transmisi	Kekuatan Sinyal (RSSI)
22/8/2024 12:00	25.1	Sukses	-90 dBm
22/08/2024 00:15	25	Sukses	-87 dBm
22/08/2024 00:30	24.9	Sukses	-89 dBm
22/08/2024 00:45	24.8	Sukses	-89 dBm
22/08/2024 01:00	24.7	Sukses	-91 dBm
22/08/2024 01:15	24.6	Sukses	-92 dBm
22/08/2024 01:30	24.5	Sukses	-90 dBm
22/08/2024 01:45	24.4	Sukses	-89 dBm
22/08/2024 02:00	24.4	Sukses	-90 dBm
22/08/2024 02:15	24.3	Sukses	-91 dBm
22/08/2024 02:30	24.3	Sukses	-90 dBm
22/08/2024 02:45	24.3	Sukses	-89 dBm

Measurement Time: Indicates when the temperature data was measured by the sensor.
Temperature (°C): The temperature value measured by the device at a specific time.
Transmission Status: Indicates whether the data was successfully sent to the LoRa gateway. The status "Success" means the data was received successfully.

Signal Strength (RSSI): An indicator of the quality of the LoRa signal during transmission, expressed in dBm (decibels relative to a milliwatt). A more negative RSSI value indicates a weaker signal. Here are the test results in figure 6

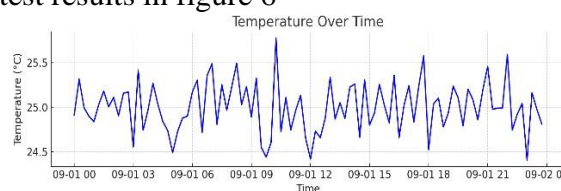

Figure 6. Temperature measurement

Lora Environmental Testing

LoRa (Long Range) communication system is a technology used for long-distance communication with low power consumption. In this system, three main parameters are tested, namely distance, RSSI (Received Signal Strength Indicator), and SNR (Signal-to-Noise Ratio). These three parameters are interrelated and greatly affect the performance and range of communication. Antennas in LORA communication play an important role as a means to spread radio waves and to receive radio wave signals at certain frequencies, the type of antenna used is the slim jim antenna shown in Figure 7. The antenna is used as a sender.

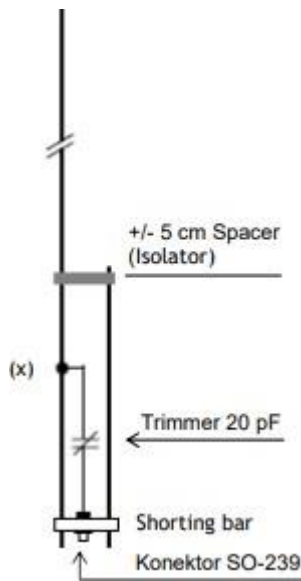

Figure 7. Slim jim antenna

LORA testing using the LoRa LXSD01 signal detector signal measuring tool

Distance

Distance is one of the most important parameters in wireless communication. The further the distance between the transmitter and receiver, the greater the decrease in signal strength and the quality of the received signal. In the LoRa system, which is designed for long distances, signals can still be received at long distances, but the quality of communication depends on the strength of the received signal and the level of interference or noise.

RSSI (Received Signal Strength Indicator)

RSSI is an indicator of the strength of the signal received by the receiver. RSSI is measured in dBm (decibel-milliwatt) and is usually a negative number. The Received Signal Strength Indicator (RSSI) is an important metric in wireless communication systems, including LoRa, to evaluate the strength of the received signal. The closer the RSSI value is to zero, the stronger the signal received. Conversely, the more negative the RSSI value is (for example, -90 dBm or lower), the weaker the signal becomes. In terms of distance, at close range, higher RSSI values (such as -40 dBm to -60 dBm) indicate a strong signal, allowing for reliable communication with higher data transfer rates. However, as the distance increases, the RSSI value begins to decrease. At medium range, the RSSI value typically falls between -60 dBm and -80 dBm, where the signal quality begins to degrade, though communication is still possible. At long range, the RSSI value can drop below -90 dBm, making the signal very weak. At this stage, the communication system struggles to maintain reliability, and the receiver may face difficulties in receiving the signal properly, leading to potential data transmission disruptions or loss. In LoRa communication, a good RSSI value (greater than -70 dBm) ensures smooth operation with minimal interference. As the RSSI decreases, the signal strength weakens, causing the receiver to experience issues with signal processing. At very low RSSI levels, communication may fail entirely, further highlighting the importance of maintaining a strong RSSI for reliable communication.

SNR (Signal-to-Noise Ratio)

SNR is the ratio of the received signal strength to the noise level in the environment. SNR

is measured in dB (decibels). The higher the SNR value, the better the quality of the received signal compared to the noise.

The relationship between SNR and distance; a) At short distances: SNR is usually high (for example, 10 dB to 6 dB), which means that the received signal is very good with little interference from noise. In this condition, communication is very stable, b) At medium distances: SNR begins to decrease (for example, 4 dB to 0 dB). At this point, noise begins to affect the signal, and communication quality begins to decrease. The system can still function, but the possibility of data errors begins to increase, c) At long distances: SNR can be negative (e.g., -2 dB to -8 dB). At negative SNR, noise dominates the signal, and communication becomes very difficult. Under these conditions, signal quality is poor, and data transmission is prone to errors or failures

Impact of SNR in LoRa communication; a) At good SNR (above 0 dB), communication is good, and data is received correctly, b) At negative SNR, especially below -5 dB, the receiver will have difficulty distinguishing the signal from the noise. Although LoRa technology has the ability to work with low SNR, communication quality is still compromised.

The overall relationship between distance, RSSI, and SNR in the LoRa communication system reveals a consistent trend: as the distance increases, both RSSI and SNR values decrease. This is a natural occurrence, as signal strength diminishes with distance while environmental noise remains constant or even intensifies. At short distances, typically below 100 meters, RSSI and SNR remain relatively high. Under these conditions, LoRa communication is highly reliable due to strong signal reception and minimal interference. When the distance extends to a medium range, approximately between 200 and 1000 meters, both RSSI and SNR begin to decline. Nevertheless, LoRa technology is engineered to operate effectively even with weak signals, enabling communication to continue, albeit with a higher potential for interference or transmission errors.

At long distances exceeding 1000 meters, signal strength becomes critically low, with RSSI values dropping below -90 dBm and SNR potentially turning negative. In such scenarios, the signal becomes increasingly difficult to differentiate from ambient noise, resulting in a significant reduction in communication quality. Successful data transmission over these extended distances typically requires enhanced hardware, such as high-gain antennas, and optimal environmental conditions that minimize interference. This overall trend and performance degradation are illustrated in Figure 8, which presents the results of testing distance, RSSI, and SNR across a range from 0 to 2000 meters in a LoRa-based communication system.



Figure 8. Distance, RSSI and SNR tests

Thus, the distance, RSSI, and SNR testing lead to several important conclusions. First, distance significantly affects both RSSI and SNR parameters. As the distance between devices increases, the values of RSSI and SNR decrease accordingly. RSSI, which represents the strength of the received signal, weakens as the separation grows, indicating reduced signal quality. Although communication can still occur at low RSSI levels, the overall transmission becomes less reliable.

Similarly, SNR, which measures the signal-to-noise ratio, also deteriorates with distance. In extreme cases, the SNR can even become negative, indicating that noise dominates the signal, making effective communication increasingly difficult. Despite these challenges, the LoRa system remains capable of receiving signals over long distances. However, when RSSI is low and SNR turns negative, the likelihood of communication errors increases. To sustain optimal performance in such conditions, appropriate hardware adjustments, such as using high-gain antennas and improving environmental factors, are essential for maintaining signal quality.

CONCLUSION

The proposed system represents a significant advancement in smart agriculture by offering an innovative solution characterized by high operational efficiency, reduced energy consumption, and extended communication range. These features are critical for improving agricultural productivity, particularly in remote and resource-limited areas. The system's ability to integrate seamlessly with existing agricultural infrastructures further enhances its applicability and relevance in real-world settings. By addressing key challenges in monitoring and data transmission, the research contributes to more sustainable and data-driven agricultural practices.

In addition, this study provides a valuable contribution to the broader field of Internet of Things (IoT) technology development, especially as applied to agriculture. By emphasizing energy optimization and long-range communication, it sets a precedent for future designs of IoT-based systems in similar domains. These findings not only reinforce the potential of IoT to revolutionize agricultural processes but also open avenues for subsequent research and innovation in smart farming technologies. Future studies are encouraged to explore scalability, interoperability, and integration with artificial intelligence to further enhance decision-making capabilities in agricultural systems.

AUTHOR CONTRIBUTIONS

Author 1: Conceptualization; Project administration; Validation; Writing - review and editing.

Author 2: Conceptualization; Data curation; Investigation.

Author 3: Data curation; Investigation.

Author 4: Formal analysis; Methodology; Writing - original draft.

CONFLICTS OF INTEREST

The authors declare no conflict of interest.

REFERENCES

- Addabbo, T. (2019). Smart Sensing in Mobility: A LoRaWAN Architecture for Pervasive Environmental Monitoring. *5th International Forum on Research and Technologies for Society and Industry: Innovation to Shape the Future, RTSI 2019 - Proceedings*, Query date: 2025-05-11 20:33:35, 421–426. <https://doi.org/10.1109/RTSI.2019.8895563>
- Alam, A. (2022). A Digital Game based Learning Approach for Effective Curriculum Transaction for Teaching-Learning of Artificial Intelligence and Machine Learning. *2022 International Conference on Sustainable Computing and Data Communication Systems (ICSCDS)*, 69–74. <https://doi.org/10.1109/ICSCDS53736.2022.9760932>
- Angraini, N. (2023). Implementation of LoRaWAN Routing Protocol in Wireless Sensor Network for Smart Compost System with LoRa Communication Module. *2023 11th International Conference on Cyber and IT Service Management, CITSM 2023*, Query date: 2025-05-11 20:33:35. <https://doi.org/10.1109/CITSM60085.2023.10455168>

-
- Atawodi, I. (2023). Comparative Analysis of RF Circuits for Interconnecting Wireless Sensor Nodes in Noisy Environments. *Conference Proceedings - IEEE SOUTHEASTCON, 2023*(Query date: 2025-05-11 20:33:35), 136–141. <https://doi.org/10.1109/SoutheastCon51012.2023.10115218>
- Batong, A. R., Murdiyati, P., & Kurniawan, A. H. (2020). Analisis Kelayakan LoRa Untuk Jaringan Komunikasi Sistem Monitoring Listrik Di Politeknik Negeri Samarinda. *PoliGrid, 1*(2), 55. <https://doi.org/10.46964/poligrid.v1i2.602>
- Biswas, S. (2021). The Firefly Unit: A MANET based communication system using Zigbee and LoRaWAN protocols for IoT applications in Remote Locations. *2021 International Conference on Advance Computing and Innovative Technologies in Engineering, ICACITE 2021*, Query date: 2025-05-11 20:33:35, 642–646. <https://doi.org/10.1109/ICACITE51222.2021.9404591>
- Flauzac, O. (2020). Comparison between different platform using a Uniform Relay Protocol in Linear Sensor Network. *ACM International Conference Proceeding Series*, Query date: 2025-05-11 20:33:35. <https://doi.org/10.1145/3423423.3423462>
- González, L. (2023). Application of LPWAN Technologies Based on LoRa in the Monitoring of Water Sources of The Andean Wetlands. *Communications in Computer and Information Science, 1706*(Query date: 2025-05-11 20:33:35), 264–278. https://doi.org/10.1007/978-3-031-28454-0_18
- González, L. (2024). A Low-Cost IoT Architecture Based on LPWAN and MQTT for Monitoring Water Resources in Andean Wetlands. *SN Computer Science, 5*(1). <https://doi.org/10.1007/s42979-023-02515-4>
- Jagadesh, T. (2023). Precision Smart Agricultural Monitoring using LoRaWAN. *International Conference for Technological Engineering and Its Applications in Sustainable Development, ICTEASD 2023*, Query date: 2025-05-11 20:33:35, 279–281. <https://doi.org/10.1109/ICTEASD57136.2023.10585007>
- Koodtalong, W., & Sangsuwan, T. (2020). Agricultural Monitoring System with Zigbee Network and PLC based on Modbus RTU Protocol. *2020 International Conference on Power, Energy and Innovations (ICPEI)*, 201–204. <https://doi.org/10.1109/ICPEI49860.2020.9431470>
- Kumar, K. (2023). An IoT-Enabled E-Nose for Remote Detection and Monitoring of Airborne Pollution Hazards Using LoRa Network Protocol. *Sensors, 23*(10). <https://doi.org/10.3390/s23104885>
- Lv, W. (2023). Application Research of Computer Network Technology in Electronic Wireless Transmission. *2023 IEEE 2nd International Conference on Electrical Engineering, Big Data and Algorithms, EEBDA 2023*, Query date: 2025-05-11 20:33:35, 1929–1933. <https://doi.org/10.1109/EEBDA56825.2023.10090488>
- Mari, J. M. (2023). The MauMe network—A LoRa multi-hop collaborative protocol and low-cost implementation example. *Computer Standards and Interfaces, 86*(Query date: 2025-05-11 20:33:35). <https://doi.org/10.1016/j.csi.2023.103733>
- Meftah, E. H. (2024). Innovative Wireless Solutions for Real-Time ECG Monitoring: Leveraging BLE, Wi-Fi, and LoRa Technologies. *Proceedings - 2024 International Conference on Telecommunications and Intelligent Systems, ICTIS 2024*, Query date: 2025-05-11 20:33:35. <https://doi.org/10.1109/ICTIS62692.2024.10894056>
- Meftahi, A. (2022). Nanocelluloses as skin biocompatible materials for skincare, cosmetics, and healthcare: Formulations, regulations, and emerging applications. *Carbohydrate Polymers, 278*(Query date: 2024-10-17 21:26:15). <https://doi.org/10.1016/j.carbpol.2021.118956>
- Netto, J. O. (2022). Implementing a Communication Network between Bases Station applied for Group of Drones. *Proceedings - 2022 IEEE 29th Annual Software Technology Conference, STC 2022*, Query date: 2025-05-11 20:33:35, 135–140. <https://doi.org/10.1109/STC55697.2022.00025>
- O. Aghenta, L., Tariq Iqbal, M., & Department of Electrical and Computer Engineering, Faculty

-
- of Engineering and Applied Science, Memorial University of Newfoundland (MUN), St. John's, NL A1B 3X5, Canada. (2020). Design and implementation of a low-cost, open source IoT-based SCADA system using ESP32 with OLED, ThingsBoard and MQTT protocol. *AIMS Electronics and Electrical Engineering*, 4(1), 57–86. <https://doi.org/10.3934/ElectrEng.2020.1.57>
- Porselvi, T. (2021). IoT based coal mine safety and health monitoring system using LoRaWAN. *2021 3rd International Conference on Signal Processing and Communication, ICPSC 2021*, Query date: 2025-05-11 20:33:35, 49–53. <https://doi.org/10.1109/ICSPC51351.2021.9451673>
- Sa'Adah, N. (2023). Tracking Position on GPS Smart Buoy System Using LoRa Communication. *2023 6th International Conference on Vocational Education and Electrical Engineering: Integrating Scalable Digital Connectivity, Intelligence Systems, and Green Technology for Education and Sustainable Community Development, ICVEE 2023 - Proceeding*, Query date: 2025-05-11 20:33:35, 304–309. <https://doi.org/10.1109/ICVEE59738.2023.10348269>
- Scherer, M. (2022). WideVision: A Low-Power, Multi-Protocol Wireless Vision Platform for Distributed Surveillance. *International Conference on Wireless and Mobile Computing, Networking and Communications*, 2022(Query date: 2025-05-11 20:33:35), 394–399. <https://doi.org/10.1109/WiMob55322.2022.9941670>
- Simanjuntak, I. U. V. (2023). Simulation and Performance Analysis of Network Backup Systems Using Hot Standby Router Protocol (HSRP) Method on Real-Time Networks. *International Journal of Electronics and Telecommunications*, 69(4), 763–768. <https://doi.org/10.24425/ijet.2023.147698>
- Simitha, K. M. (2019). IoT and WSN Based Water Quality Monitoring System. *Proceedings of the 3rd International Conference on Electronics and Communication and Aerospace Technology, ICECA 2019*, Query date: 2025-05-11 20:33:35, 205–210. <https://doi.org/10.1109/ICECA.2019.8821859>
- Siregar, B. (2020). LPG leak detection system using MQTT protocol on LoRa communication module. *2020 4th International Conference on Electrical, Telecommunication and Computer Engineering, ELTICOM 2020 - Proceedings*, Query date: 2025-05-11 20:33:35, 215–218. <https://doi.org/10.1109/ELTICOM50775.2020.9230518>
- Sun, S. (2024). Design of LoRa-based multi-parameters river water quality monitoring system. *2024 9th International Symposium on Computer and Information Processing Technology, ISCIPT 2024*, Query date: 2025-05-11 20:33:35, 121–125. <https://doi.org/10.1109/ISCIPT61983.2024.10673138>
- Wu, Y. H. (2019). The two-level group network meter reading system based on SX1278. *Proceedings of SPIE - The International Society for Optical Engineering*, 11048(Query date: 2025-05-11 20:33:35). <https://doi.org/10.1117/12.2522643>
- You, Z. (2022). Design and Experiment of Seed Combine Harvester for Chinese Milk Vetch Green Manure in Paddy Field. *Nongye Jixie Xuebao/Transactions of the Chinese Society for Agricultural Machinery*, 53(Query date: 2024-07-17 17:53:26). <https://doi.org/10.6041/j.issn.1000-1298.2022.S2.001>
- Zare, A., & Iqbal, M. T. (2020). Low-Cost ESP32, Raspberry Pi, Node-Red, and MQTT Protocol Based SCADA System. *2020 IEEE International IOT, Electronics and Mechatronics Conference (IEMTRONICS)*, 1–5. <https://doi.org/10.1109/IEMTRONICS51293.2020.9216412>
-

Copyright Holder :

© Yani Prabowo et al. (2025).

First Publication Right :

© Journal of Computer Science Advancements

This article is under:

